

**CARIBBEAN EXAMINATIONS COUNCIL**

**REPORT ON CANDIDATES' WORK IN THE  
SECONDARY EDUCATION CERTIFICATE EXAMINATION**

**MAY/JUNE 2010**

**BUILDING TECHNOLOGY  
OPTION II – CONSTRUCTION**

**Copyright 2010 Caribbean Examinations Council  
St Michael, Barbados  
All rights reserved.**

## GENERAL COMMENTS

This year, 2010, 1 912 candidates wrote the Building Technology Construction examination. This was 25.29 per cent more than the 1526 who wrote the examination in 2009. Of these, 81 per cent obtained Grades I – III compared with 2009.

The Building Technology examination consists of three papers:

Paper 01 – Multiple Choice (consisting of 60 items)

Paper 02 – Structured Restricted Response (essay questions)

Paper 03 – School-Based Assessment (SBA)

Candidates performed creditably on the practical projects of the SBA; however, the written assignment continues to present a challenge. There appears to be a degree of uncertainty on the part of both teachers and students in terms of the correct format in which the SBA should be presented. Perhaps the mark scheme needs to be modified in order to simplify the marking of the written assignment.

Candidates seemed knowledgeable in a wide range of topics in the syllabus but were unable to apply that knowledge when required to do so in the application questions in Paper 02. The conclusion therefore is that not enough practical time is allocated for candidates to develop competencies that would allow them to improve their overall performance in the examination. This issue must be addressed urgently in order to sustain comparable performances in successive examinations.

It is hoped that teachers will use the practical assignment to teach more of the related building principles, technologies and science inherent in the various modules in the syllabus.

- (1) Question 1 of the examination is compulsory and is based on Modules D5 – D9 which covers walls, floors, roofs, doors, windows and stairs. This question is worth 40 marks. Over the years, approximately 30 per cent of the candidates would complete this question. This inevitably impacts negatively on the overall performance of Paper 02. There is need for a critical analysis of the factors contributing to the poor performance of candidates on Question 1.

Discussions on the above mentioned issue between the examination committee and the diverse group of examiners and assistant examiners from a large cross section of the Caribbean revealed that the major factors are:

- Candidates lack the prerequisite knowledge of the constructional procedures and techniques used to put building components together for example, doors, windows, floors, roofs and stairs. This hinders their ability to respond to questions requiring them to produce sectional sketches of those building components. Unfortunately the need to produce sectional sketches is inevitable because Section 1 of the syllabus deals specifically with details/sectional drawings of building components and Question 1 is designed to test candidates' skills in that area.

- Candidates' poor drawing/sketching skills continue to hinder their ability to perform creditably, especially on Question I. The skill of producing and interpreting detailed sectional drawings/sketches is one that must be fully developed by all candidates with an interest in the field of Building Construction. Drawing/sketching is the language of the construction industry. Therefore, every effort must be made to equip candidates with good drawing/sketching skills.
- (2) Candidates must be reminded to use the drawing paper attached to the answer booklet to answer **only** the compulsory question 1, in Section A. This point may be reiterated as it continues to cause problems during the marking exercise.

## **DETAILED COMMENTS**

### **Paper 01 - Multiple Choice**

This paper comprised a total of 60 multiple choice items based on all the theoretical aspects of the syllabus. Candidates responded reasonably well to most of the questions. However, their responses to some of the questions clearly suggested that they were not adequately prepared for the examination. Teachers should note the units, specific objectives and related content indicated in the syllabus and use this to ensure that students are adequately prepared for the examination.

### **Paper 02 - Structured Restricted Response Essay Questions**

This was a free response paper with three sections A, B and C. Each question received equal weighting for the profile dimensions Knowledge and Application.

- Section A      This consisted of one compulsory design question based on Modules D5 – D9 of the syllabus.
- The question is worth 40 marks
- Section B      This contained five questions based on Modules D2 – D10 of the syllabus of which candidates were expected to answer three questions. The questions were worth 20 marks each.
- Section C      This comprised three questions based on Modules D11 – D13 of the syllabus of which candidates were expected to answer one question. The question is worth 20 marks.

## Section A

### Question 1

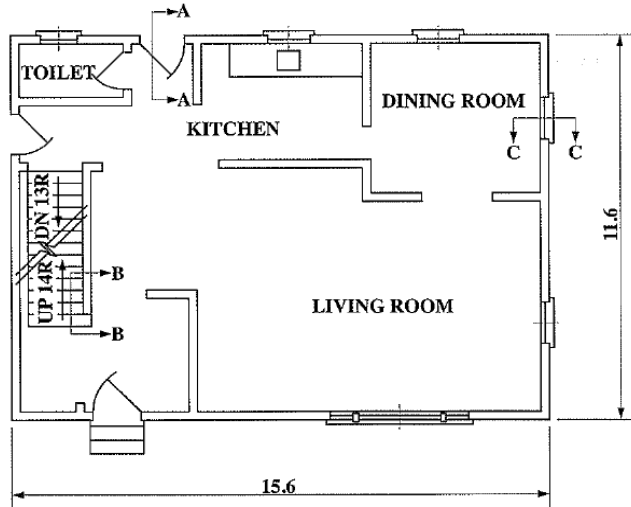

Figure 1. Floor plan

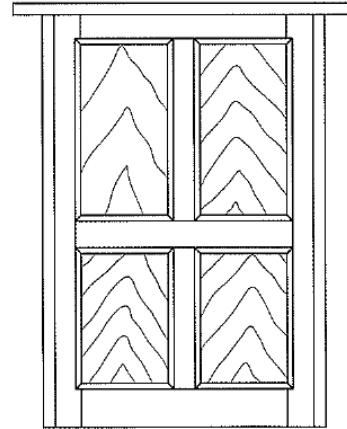

Figure 2. Door and frame

This was a compulsory design question which comprised five parts designed to test candidates' knowledge and understanding of best practices adopted in the construction industry when working on

- i) doors and door frames
- ii) walls
- iii) timber staircases

Candidates were presented with a floor plan and the front elevation of a panelled door and frame (see Figures 1 and 2).

Part (a) tested candidates' ability to demonstrate their understanding of the constructional details of a panelled door and frame. This part of the question required candidates to produce a sketch of a vertical section of the door and frame at A-A on the floor plan. Details of the foundation and walls were not required.

Candidates who were better prepared for the examination performed creditably. However, weaker candidates found this question very challenging. Though they encountered difficulties producing the sketch of the vertical section, they were able to produce correct details of the foundation, wall and roof which were not required.

Parts (b) (i) and (ii) tested candidates' knowledge of the type of door and its respective parts. This part of the question was generally well done. However, weaker candidates referred to 'Muntin' as 'Mullion' and 'Middle Rail' as 'Intermediate Rail'. Also, candidates named the parts of the door frame as part of the door. The question particularly asked candidates to label six parts of the door in Figure 2 (not the door and frame).

Part (c) tested candidates' ability to demonstrate an understanding of the constructional details of a window opening in a wall. This part of the question required candidates to produce a labelled sketch of a vertical section through the wall at section C-C on the floor plan to show details of the Concrete Sill and Lintel. Details of the window and frame were not required. This was generally well done.

Parts (d) (i), (ii) and (iii) tested candidates' knowledge of anti-capillary grooves, their purpose and where they can be found in buildings. Many candidates showed little or no knowledge of this constructional feature. This may be because it is not being taught. Teachers are therefore encouraged to teach all the topics in the syllabus (Note the section of the syllabus that deals with anti-capillary grooves is D8.2: 6).

Part (e) tested candidates' understanding of wooden stair constructional techniques.

Part (e) required candidates to

- (i) produce a labelled vertical section of the stair at B-B on the plan view in Figure 1 to show how one riser and one tread are connected together, and
- (ii) give the function of a riser, tread, headroom, handrail, balustrade and newel post in relation to stairs.

See appendix 1 for sample responses to Question 1.

## **Section B**

### Question 2

This was one of the popular questions in Section B. It tested candidates' knowledge and understanding in the areas of

- (i) site preparation and
- (ii) basic site management

Part (a) required candidates to list five factors affecting the choice of a building site. This part of the question was very well done.

Part (b) (i) required candidates to list five reasons for hoarding a building site and (b) (ii) required them to write brief explanatory notes for each reason given in (b) (i). This part of the question was a bit challenging for candidates, perhaps because of their inability to express themselves properly in writing.

In Part (c), candidates were asked to state three reasons for stripping a building site, candidates performed very well on this part. Part (d) required candidates to give one example of a temporary service and one example of a temporary shelter. This part posed a problem for the weaker candidates who were in the habit of simply listing temporary services and shelters.

This was one of the popular questions in section B.

See appendix 2 for sample responses to Question 2.

### Question 3

This was a very popular question. It tested candidates' knowledge and understanding of different building materials and their uses in the construction industry, for example timber, concrete, mortar and plastics.

Part (a) required that candidates sketch a cross-section of a tree trunk and label six parts. This was generally very well done. However, in labelling, some candidates did not correctly identify the parts.

Parts (b) (i) and (ii) required candidates to define the terms *concrete* and *mortar*. Generally, the question was well done. However, in their responses weaker candidates omitted stating that the ingredients are 'mixed in correct proportion'.

Part (c) asked candidates to explain the term *moist curing* as it relates to concrete. This was not very well done as candidates demonstrated very little knowledge of this concept in building construction.

Part (d) required candidates to list four properties of plastics used in the building construction industry. This part of the question was very well done.

See appendix 3 for sample response to Question 3.

### Question 4

This question tested candidates' knowledge and understanding of foundations and their functions. It also tested their knowledge of different types of brick bonds, functions of external walls and the meaning of the term *proportioning* as it relates to concrete.

Part (a) required candidates to use labelled sketches to illustrate Simple Strip foundation, Raft foundation and Pad foundation. The lack of drawing skill displayed by candidates hindered their chances of performing well on this part of the question.

Part (b) required candidates to state two functions of a foundation. This part of the question was very well done. In Part (c), candidates were asked to list three different types of brick bonds. Candidates did not perform as expected on this question. They listed a series of incorrect names.

Part (d) required candidates to state three functions of the external walls of a building. The response to this part of the question was good. For Part (e) candidates were asked to define the term *proportioning* as it relates to concrete. Most candidates displayed a good knowledge of the term *proportioning*

See appendix 4 for sample responses to Question 4.

### Question 5

This was the least popular choice in Section B. It tested candidates' knowledge and understanding of floors (both reinforced concrete and timber), their functions and construction.

In Part (a), candidates were asked to produce a neatly labelled sketch to show a vertical section through a reinforced concrete ground floor with a 19 mm cement sand screed. Candidates perform well on this part of the question.

Part (b) required candidates to state five functional requirements of floors. The better candidates performed well on this part. The weaker candidates found it difficult to list five functional requirements of floors, perhaps because of their inability to express themselves properly.

Part (c) required candidates to state two methods of strutting as they relate to upper timber floors. Performance on this part of the question was not very good as candidates seemed to have little knowledge of strutting.

Part (d) required candidates to list three members of a timber floor. This was well done.

The overall response to this question was very poor.

See appendix 5 for sample responses to Question 5.

### Question 6

This question tested candidates' knowledge and understanding of different types of roofs and their construction.

Part (a) required candidates to produce single line diagrams to illustrate Lean-to roof, Gable roof, Close couple roof, Hip roof and Hip and valley roof and identify them by inserting the correct names next to each sketch. This part of the question was generally well done.

Part (b) required candidates to state three advantages of trussed roof construction over other types of construction systems. Candidates responded well to this part of the question.

In Part (c), candidates were required to name four different types of roof coverings. This was well done.

Part (d) required candidates to name three members of a close couple roof. Candidates did not seem to have a good understanding of the structural members of a close couple roof.

See appendix 6 for sample responses to Question 6.

## Section C

### Question 7

This question tested candidates' knowledge and understanding of drainage systems.

In Part (a), candidates were asked to write brief explanatory notes on the purpose of a *soakaway*. For Part (b), they were asked to briefly explain two advantages and two disadvantages of (i) a combined system of drainage and (ii) a separate drainage system.

Part (c) required candidates to explain the following terms: *cesspool, surface-water drain, sewer, sewage and drain pipe*.

Candidates seemed to have very little knowledge of drainage systems and terms associated with drainage. This, perhaps, may be owing to a lack of exposure to the topic. Teachers should use field trips to allow their students to gain knowledge in that important area of building construction.

See appendix 7 for sample responses to Question 7.

### Question 8

This question tested candidates' knowledge and understanding of the duties of the members of the building team and the building trades on a construction project/site.

Part (a) required candidates to explain the functions of the following members of the building team: *client, architect, contractor, engineer and quantity surveyor*.

Part (b) asked candidates to state two functions of each of the following persons in the building trades: *carpenter, electrician, plumber, painter and mason*.

This was a very popular question in Section C and candidates seemed to have performed reasonably well on both parts.

See appendix 8 for sample responses to Question 8.

### Question 9

This question tested candidates' knowledge and understanding of architectural features from Britain and the USA that have influenced the design of buildings in the Caribbean. It also tested candidates' knowledge of factors that influence building design.

Part (a) required candidates to explain five factors that influence the design of a building. In Part (b), building features from Britain and the USA that have influenced building design in the Caribbean were explored.

Very few candidates attempted this question. This has been the trend over the years and this may be the result of the topic not being taught.

See appendix 9 for sample responses to Question 9.

### School-Based Assessment (SBA)

The SBA is intended to be a diagnostic, formative and summative assessment tool. Students can present their best efforts once the suggested time frame is followed by teachers. The new format requiring both a practical and written project should be taken seriously if students are to develop the intended competencies.

Students are required to complete two assignments during terms four and five (terms one and two of the examination year) and each candidate is required to complete

- (i) One practical project to be selected from a list of three published by CXC. This will be worth 90 marks for profile dimension 3 (Practical Ability).
  - (ii) *A written assignment set by the classroom teacher in keeping with the guidelines outlined by CXC and based on the Common Modules D1, D14 and D15. This will be worth 30 marks for profile dimension 3 (Practical Ability).*
1. This year's moderation analysis revealed that, across territories, *many candidates' written reports were reproductions of a single report.* Also, some candidates seem to be reusing previous years' reports. This unacceptable practice may have negatively affected candidates' overall scores. Teachers' assessment of the written reports appeared to be quite generous and in some instances, contrary to the suggested mark scheme.
  2. A major aspect of the SBA practical project is design which entails drawing, material, various machines, manual processes and the evaluation of various methods and systems in Building Technology. This aspect of the programme must be managed by the teacher, if students are to derive maximum benefit such as drawing skills and the ability to relate theory to practice.

The format developed to ensure that the skills are organized systematically includes the following:

1. Preliminary considerations (usually a statement of what the student wants to do)
2. Preliminary design
3. A pictorial sketch of the project idea
4. Production of a set of working drawings (orthographic, including sectional views)
5. Estimating the quantities and types of material and cost
6. Selecting appropriate materials (or suitable alternatives)
7. Selecting tools and machinery
8. Developing a plan of operations
9. Implementing a plan of operations, in order to complete the project
10. Supervision of team members and coordination of various operations

Item 10 is very important. A series of practical exercises should be developed by the teacher and administered to students. While this is being done, the teacher should observe the students and identify those who exhibit a greater sense of responsibility and mastery of the related skills. These individuals should be used to assist or lead small groups (3–5) in completing larger and more difficult projects.

### **RECOMMENDATIONS TO TEACHERS**

General recommendations to teachers for previous years are repeated here for those who are new and for those who may not have seen them before. However, all teachers are encouraged to pay attention to the suggestions which follow in an effort to improve students' overall performance in the examination.

1. Students must be encouraged to read the examination questions carefully and follow instructions precisely as valuable time can be wasted producing work that will not produce extra marks.
2. Students should be given opportunities to produce more detailed sectional sketches so as to assist in improving their knowledge and understanding of vertical and horizontal sections of buildings and building components.
3. Staircase details, design (stair calculations) and construction require serious attention. In this regard, it is suggested that teaching aids be used, for example, models and charts should be displayed in the laboratories/workshops depicting different types of stairs, building regulations pertaining to stairs, labelled sectional sketches of stairs (both wooden and concrete).
4. Where possible, students should practice setting out buildings of different shapes both on flat and sloping sites on the school's campus if no other site can be found.
5. Where possible, field trips should be organized to a cement plant and other manufacturing plants related to the construction industry. Plastic, for example, is a widely used material in the construction industry. Most plumbing pipes and a wide range of fittings (for example, electrical conduits and concrete forms) are made of plastic. Teachers should therefore expose students to these materials very early.
6. Types of floor finishes should be taught theoretically and practically.
7. Students should be constantly reminded that all sketches must be labelled as marks are always awarded for labelling.
8. Charts showing different types of brick bonds should be displayed in the lab/workshop.
9. Sanitary appliances, plumbing fixtures, drainage and sewage disposal are very important to the overall functioning of buildings. Therefore, the relevant sections of the syllabus which deal with these must be taught thoroughly.

10. Most communities in the Caribbean have historic buildings in existence. They are either of timber or brick construction. Students should be encouraged to visit them and observe their architectural design and main features. Recommendations 8 and 9 will enable candidates to improve their responses to questions in Section C of the syllabus.
11. Particular attention should be paid to Question 1 in Paper 02. This question is worth 40 marks and usually requires candidates to produce a number of detailed sketches. Candidates who are not skilled at sketching are likely to find this question very challenging. Therefore, teachers are encouraged to provide students with opportunities/activities to help them develop their sketching skills. **NOTE: Always remind students that only Question 1 should be done on the drawing paper provided for the examination. All other questions must be done in the answer booklet.**
12. Since scale drawing is no longer required, candidates must note that well-proportioned sketches should be produced. Additionally, candidates must acquire a good knowledge of constructional details of both wooden and concrete structures in order to perform well on the question.
13. Where a section of the syllabus proves to be beyond the delivery capabilities of the teacher, it is suggested that he/she solicits the help of resource persons to assist. **NOTE: This is especially important when the section contain hands-on practical work.**

## Appendix 1

### Section A

#### Sample responses to Question 1

1. (a) Vertical Section of door and frame at A-A on plan of Figure 1

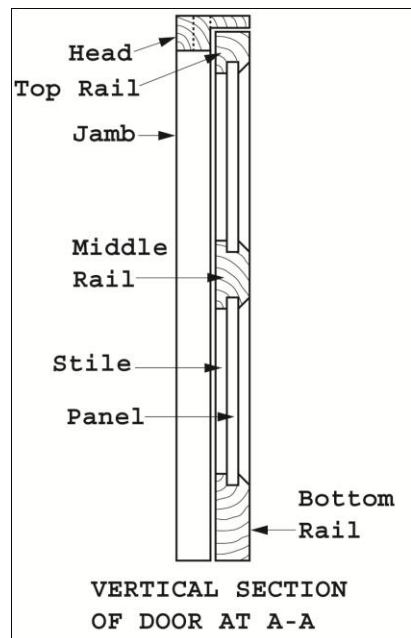

- (b) (i) Correct name of door in Figure 2  
Four Panel Door
- (ii) Six parts of the door in Figure 2
1. Top rail
  2. Middle rail
  3. Bottom rail
  4. Panel
  5. Stile
  6. Muntin
- (c) Labelled vertical section showing details of concrete sill and lintel at Section C-C on the floor plan in Figure 1.

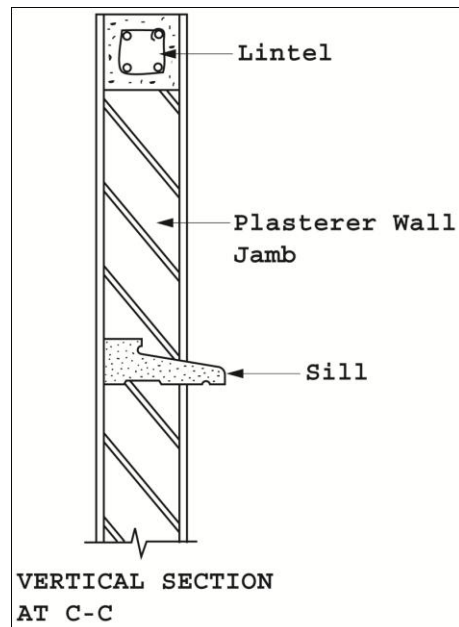

- (d) (i) Explanation for the term 'anti-capillary groove':
- Anti-capillary groove refers to the grooves that are strategically placed in concrete or wood which will extend beyond the exterior part of a building or structure.
- (ii) Purpose of anti-capillary grooves:
- To prevent water or moisture from getting into a building or structure by ensuring there is a break which would allow water to drip off.
- (iii) Two places where anti-capillary grooves can be found:
- Anti-capillary grooves can be found on the under sides of concrete sills and beams, drips, door and window frames.

- (e) (i) Labelled vertical section of the stair at B-B showing how one riser and one tread are joined to each other.

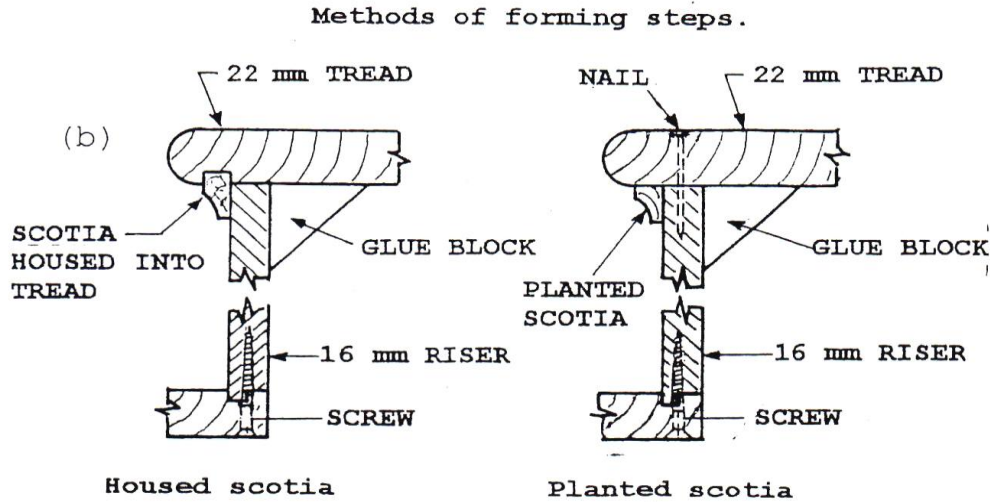

Functions:

1. Riser – encloses the space between two consecutive treads in a flight. It also gives support to the tread.
2. Tread – provides a platform for climbing the stair.
3. Headroom – the clear vertical height measured from the ceiling to the nosing of the step which provides unobstructed access from floor to floor.
4. Handrail – provides support to the user when climbing or descending the stair.
5. Balustrade – provides protection to the sides of the stair so persons do not fall off at a height.
6. Newel post – provides support for the handrail and the staircase.

## Appendix 2

### Section B

#### Sample responses to Question 2

2. (a) Factors affecting the choice of a building site.

- Accessibility
- Climate
- Availability of services
- Regulations
- Topograph
- History
- Soil type
- Zoning
- Cost
- Aspect

(b) (i) Reasons for hoarding:

- Public protection
- Material/equipment protection
- Security
- Reduces vandalism
- Prevents interruption

(ii) Explanatory notes for reasons given:

Public protection – to reduce the risk of accidents by keeping activities on the site away from outside persons.

Material/equipment protection – to reduce theft of materials.

Security – to ensure workers and equipment are safe on the site.

Reduces vandalism – prevents persons from interfering or destroying items on the site.

Prevents interruption – persons or animals from the outside would not be able to distract workers on the site.

(c) Reasons for stripping a building site:

1. Removal of top soil
2. Reducing instability of top soil
3. Removal of vegetation

(d) Examples of temporary services:

1. Light
2. Water
3. Telephone

Examples of temporary shelters:

1. Site office
2. Toilet
3. Changing room

### Appendix 3

#### Sample responses to Question 3

(a) Sketch of cross-section of tree trunk with six parts labelled

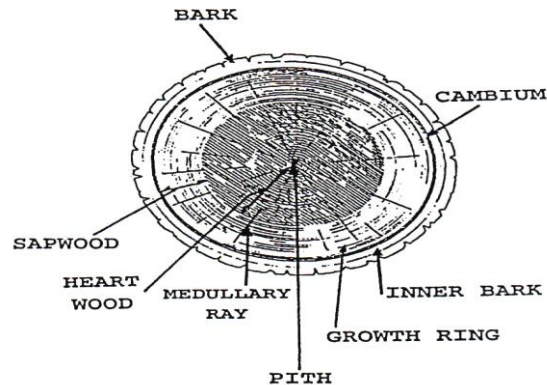

(b) (i) Definition for concrete and its use:

A mixture of cement, sand, gravel and water in the correct proportion to form a paste that can be moulded into any shape. Concrete is used to make columns, beams, etc.

(ii) Definition of mortar and its use:

Cement, sand and water mixed in correct proportion. Mortar is used for making beds, for laying bricks and for rendering masonry walls.

(c) Explanation of the term 'moist curing':

This is a process of wetting concrete that has set to ensure that the process of hydration continues to develop the required strength of the concrete and prevents shrinkage due to rapid drying of the concrete.

(d) Properties of plastics used in the building construction industry

They are:

- (i) Lightweight
- (ii) Strong
- (iii) Pliable
- (iv) Waterproof
- (v) Non-conductor
- (vi) Rustproof
- (vii) Can revert to their natural state

#### Appendix 4

##### Sample responses to Question 4

Labelled sketches

(a) (i) Simple strip foundation

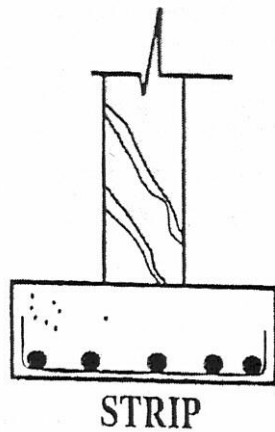

(ii) Raft foundation

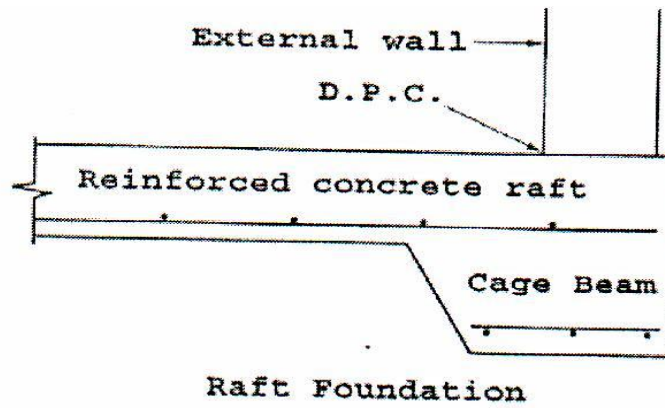

(iii) Pad foundation

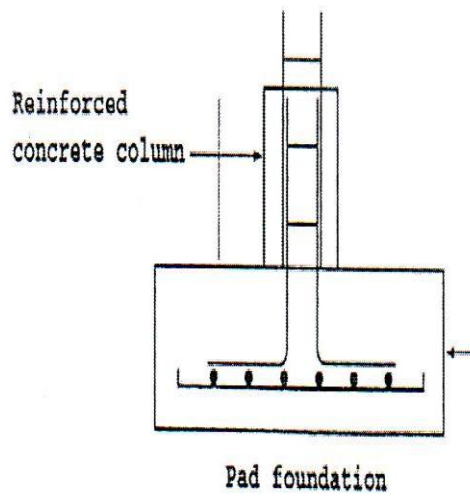

(b) Functions of foundation:

- (i) Distributes loads
- (ii) Anchors the building
- (iii) Provides stability

(c) Different types of brick bonds:

- (i) Flemish bond
- (ii) English bond
- (iii) Stretcher bond

(d) Functions of external walls of a building:

- (i) Encloses a building
- (ii) Protection from the elements
- (iii) Load bearing

(e) Definition of the term 'proportioning' as it relates to concrete:

This is a method of measuring the ingredients of a concrete mix to maintain consistency in strength and durability.

### Appendix 5

#### Sample responses to Question 5

(a) Labelled sketch of a vertical section through a reinforced solid concrete ground floor with a 19 mm cement sand screed

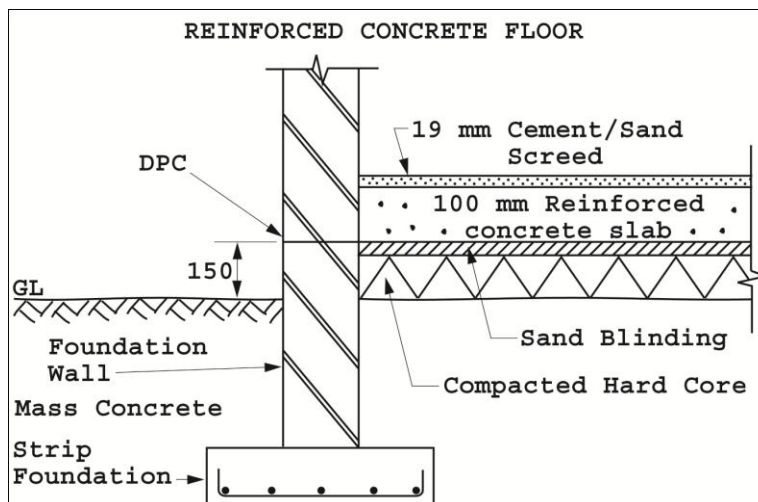

(b) Functional requirements of floors

The floor should be:

1. Stable
2. Even
3. Level
4. Resistant to wear
5. Durable
6. Aesthetically pleasing

(c) Two methods of strutting as they relate to upper timber floors:

1. Solid strutting
2. Herring bone strutting

(d) Three members of a timber floor:

1. Wall plate
2. Common joist
3. Joist hangers
4. Floor boards
5. Binder

## **Appendix 6**

### Sample responses to Question 6

- (a) Single line diagrams of different types of roofs.

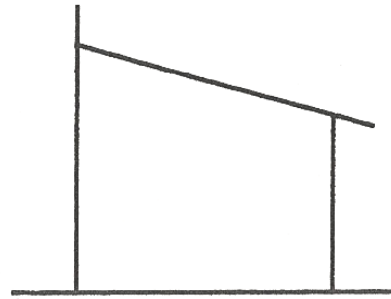

**LEAN-TO ROOF**

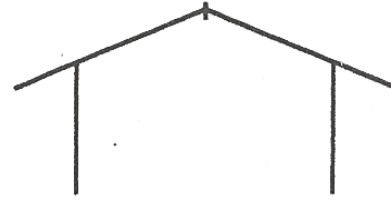

**GABLE ROOF**

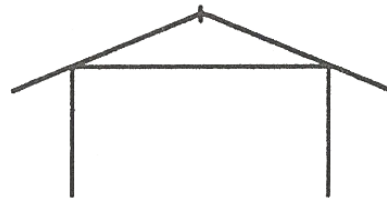

**CLOSED COUPLE  
ROOF**

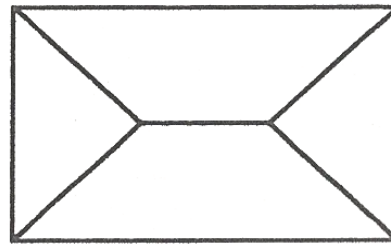

**HIP ROOF**

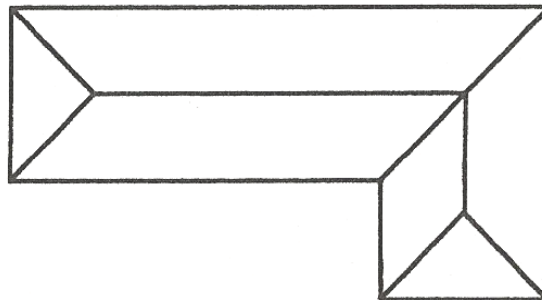

**HIP & VALLEY ROOF**

(b) Advantages of truss roof construction over other types of construction systems:

- (i) Easy to fabricate
  - (ii) Less time needed to erect
  - (iii) Costs less
  - (iv) Quality can be controlled
  - (v) Stronger
- (c) Types of roof covering:

- (i) Corrugated galvanized sheets
  - (ii) Asphalt shingles
  - (iii) Roof tiles
  - (iv) Slate
  - (v) Wood shingles
- (d) Parts of a close couple roof:
- (i) Common rafter
  - (ii) Ridge
  - (iii) Tie
  - (iv) Wall plate
  - (v) Fascia board

## Appendix 7

### Section C

#### Sample responses to Question 7

- (a) Explanatory notes on the purpose of a 'soakaway':
- This is a pit dug in permeable ground which receives the water discharge from the roof and paved areas of building and allows the water to percolate into the surrounding subsoil
- (b) Advantages and disadvantages of a combined system of drainage and a separate drainage system
- (i) Advantages of a combined system of drainage:
- Very easy to maintain
  - All drains are flushed when it rains
  - It is impossible to connect to the wrong sewer
- Disadvantages of a combined system of drainage
- All discharge must pass through the sewage treatment installation
  - When it rains heavily there is the possibility of overflow of the septic tank
- (ii) Advantages of a separate drainage system:

- One sewer receives the surface water discharge and conveys this directly to suitable out fall without treatment
- There is no chance of over flow during heavy rains

Disadvantages of a separate drainage system:

- There is the risk of connecting to the wrong sewer line
- Soil drains are not flushed during heavy rains

(c) Explanation of drainage terms:

- (i) Cesspool – an underground chamber constructed for the reception and storage of foul water from the building until it is emptied.
- (ii) Surface – water drain – drain designed to carry only surface water, rather than soil or waste.
- (iii) Sewer – pipe or closed channel that carries sewage.
- (iv) Sewage – domestic waste matter that is carried away by water in a system of sewer drains.
- (v) Drain pipe – pipe designed to carry waste water or sewage from the building.

## **Appendix 8**

### Sample responses to Question 8

(a) Functions of the members of the Building Team

Client – the person who commissions the work and directly or indirectly employs everybody on the project.

Architect – engaged by the client as his/her agent to design, advise and ensure that the project is keeping within cost and complies with the design.

Contractor – employed by the client on the architect's advice to carry out the constructional works. He takes his instructions from the architect.

Engineer – a specialist such as a structural engineer employed to work with the architect on particular aspects of the design.

Quantity surveyor – engaged to prepare bills of quantities, check tenders, prepare interim valuations and advise the architect on the cost of variations.

(b) Function of members of the building trades:

Carpenter – erects structural framework and constructs roofs

Electrician – carries out wiring works and installation of fixtures

Plumber – lay pipes, install taps, toilet bowls, etc.

Painter – responsible for finishing the building by applying paint, wall paper, etc.

Mason/tiler – works with concrete and mortar, lay concrete blocks, plaster walls etc.

## Appendix 9

### Sample responses to Question 9

(a) Factors influencing the design of a building:

- (i) History – history of the site, is it prone to flooding or land slide? Is it built-up? What was its previous use?
- (ii) Material – choice and availability of materials
- (iii) Culture – influences the shape and style of the structure. Family custom.
- (iv) Climate – wet, hot, cold, windy, would determine where windows or balconies are placed in a building
- (v) Cost – determines affordability

(b) Labelled sketches illustrating different **French** or **English** architectural features that have influenced building design in the Caribbean

Brickwork – is still in use in the Caribbean, so is the *wooden casement window*. *The steep roofs* have been adopted since we build roofs which are covered with shingles. *Arches* are very common throughout the Caribbean so are *staircases with balusters*, all of which are from British and French cultures.

